

# EMERALD

**LED WEATHERPROOF IP65 BULKHEAD  
MULTIMODE EMERGENCY LIGHT**

This multimode LED emergency luminaire is designed to provide a low-glare, high-transmission general light source whilst producing brilliant illumination under emergency conditions to cover large escape paths and areas.

Available in a robust IP65-rated square die-cast enclosure, the Emerald is a long-term emergency lighting solution for general areas such as stairwells, apartments, commercial properties and car parks.

- D80
- MICROWAVE SENSOR OPTION
- pf > 0.95  
120° beam  
CRI > 84
- 100,000hr LED
- WALL OR CEILING MOUNT
- IP65 IK10
- 3 YEAR WARRANTY
- AUSTRALIAN OWNED



Available as:

- Single Point
- STAR  
Self-Test and Reporting
- DALI
- SYNECTIX RF

Project Name	Type	Qty
Comments		

## Technical Specifications

Item	Part Number	EMS-BULKSQ	STD-BULKSQ
	Description	20W LED 4000K Multimode Weatherproof IP65 Emergency Bulkhead c/w Synthium™ Battery	20W LED 4000K Weatherproof IP65 Bulkhead (Non-Emergency)
Input	Voltage & Frequency	230VAC ; 50Hz	
	Installation	Large terminal block and 20mm <sup>2</sup> cable entry	
Output	Light Source	20W 2400lm 4000K High Performance Osram LED Array - 100,000 hours	
	Mode of Operation	Multimode - Maintained / Non-Maintained / Switchable	Non-emergency
	Power Consumption	25W (Maintained), 5W (Non-Maintained)	23W
	Emergency Duration	> 120 minutes	N/A
Controls	Charger	Intelligent 3-stage charger with Synthium™	
	Protection	Overcharge, low voltage disconnect, overcurrent, short circuit	
	Testing Facility	Manual test switch	
	Indicators	Battery charger green LED	
Physical	Construction	Diffuser - high transmission translucent polycarbonate, Chassis - die-cast aluminium	
	Mounting	Surface mounted - ceiling or wall	
	Dimensions L x W x H	315mm x 315mm x 100mm	
	IP / IK Rating	IP65 / IK10	
	Weight	3.0kg	
	Warranty	3 years	
Environment	Operating Temperature	1° to 40°C	
	Relative Humidity	0 to 95%	
Compliance	Standards	RCM / EMC, AS/NZS 2293, AS/NZS 60598.1	
	AS/NZS 2293 Classification	C0 D80 C90 D80	N/A
Accessories	Microwave Dimming Sensor	P/N: include suffix "/MWS" e.g. EMS-BULKSQ/MWS	
	STAR™ Self-Test and Reporting	P/N: EMS-BULKSQ/ST	
	DALI-compatible	P/N: EMS-BULKSQ/DL	
	SYNECTIX™ RF Wireless	P/N: EMS-BULKSQ/RF	
	Replacement Battery	P/N: BAT-BULKSQ; Synthium™ LiFePO <sub>4</sub>	

NOTE: Product specifications subject to change without prior notice due to ongoing product improvement policy and changes to industry standards.

## Dimensions

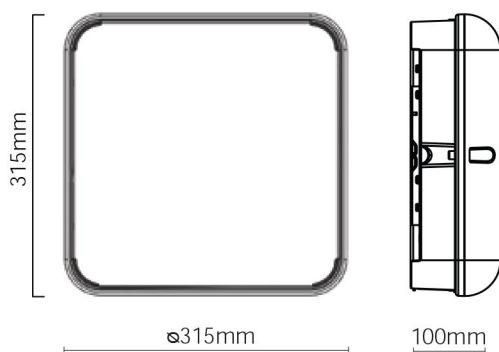

## AS/NZS 2293.1:2018 Spacing Table

SPACING TABLE	MOUNTING HEIGHT (m)								
NATA Classification	2.1	2.4	2.7	3.0	4.0	5.0	6.0	8.0	10.0
C0 - D80	11.5	13.2	14.8	16.5	22.0	27.5	28.9	30.9	32.1
C90 - D80	11.5	13.2	14.8	16.5	22.0	27.5	28.9	30.9	32.1

MB Lights

info@mblights.com.au

[ [click here](#) for product enquiry ]

THANKS  
FOR THE  
love