

EMERGENSEE™ PRO

D80 LED - RECESSED MOUNTED
NON-MAINTAINED EMERGENCY LIGHT

The EmergenSee™ Pro's lifetime-warranted LEDs deliver an unobtrusive, ultra bright source of illumination intended to alleviate panic and establish a safe, distinct and efficient egress path in the event of an emergency.

This award-winning range comes as a recessible disc that can be recessed into a ceiling cavity. It can be used in almost all internal general applications including offices, shopping centres, commercial properties, and residential buildings.



Australian Standard
AS/NZS 2293



Available as:



Project Name	Type	Qty
Comments		

Technical Specifications

Item	Part Number	EMS-PRO
	Description	D80 LED Recessed Non-Maintained Emergency Light c/w Synthium™ Battery
Input	Voltage & Frequency	230VAC ; 50Hz
	Installation	Complete with 1.2m flex cable & plug
Output	Light Source	High performance Twin 3W LED with Syclops™ optical lens - lifetime warranty
	Mode of Operation	Non-Maintained
	Power Consumption	2W (standby)
	Emergency Duration	> 120 minutes
Controls	Charger	16hr intelligent 3-stage charger with Synthium™ battery management system
	Protection	Overcharge, low voltage disconnect, overcurrent, short circuit
	Testing Facility	Manual test switch
	Indicators	Battery charger green LED
Physical	Construction	Flame-retardant polycarbonate
	Mounting	Recessed - ceiling, 70 - 150mm cut-out
	Dimensions L x W x H	Disc: 100mm or 160mm diameter
	IP Rating	IP20
	Weight	1.0kg
	Warranty	5 years
Environment	Operating Temperature	1° to 40°C
	Relative Humidity	0 to 95%
Compliance	Standards	RCM / EMC, AS/NZS 2293, AS/NZS 60598.1
	AS/NZS 2293 Classification	C0 D80 C90 D80
Accessories	STAR™ Self-Test and Reporting	P/N: EMS-PRO/ST
	DALI-compatible	P/N: EMS-PRO/DL
	SYNECTIX™ RF Wireless	P/N: EMS-PRO/RF
	Replacement Battery	P/N: BAT-PRO: Synthium™ LiFePO ₄

NOTE: Product specifications subject to change without prior notice due to ongoing product improvement policy and changes to industry standards.

Dimensions

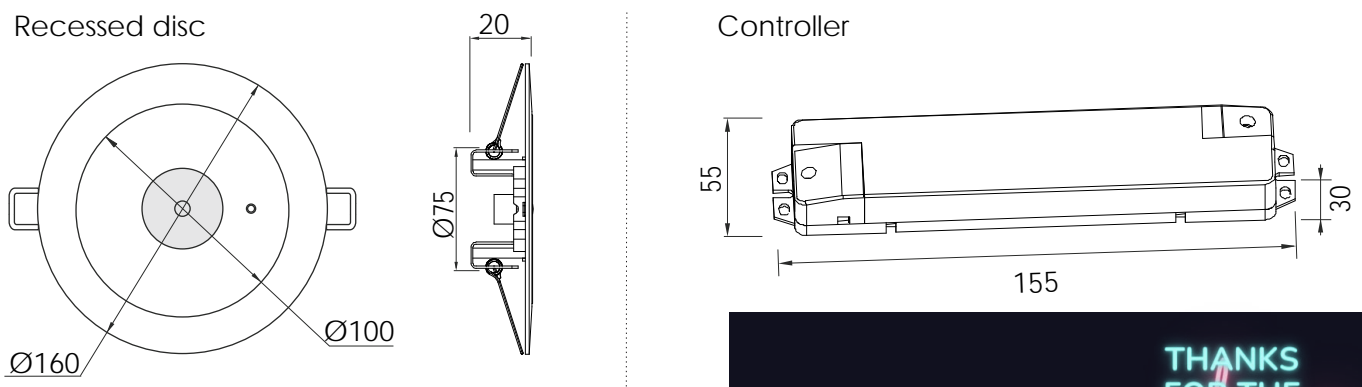

AS/NZS 2293.1:2018 Spacing Table

SPACING TABLE	MOUNTING HEIGHT (m)								
	2.1	2.4	2.7	3.0	4.0	5.0	6.0	8.0	10.0
NATA Classification									
C0 - D80	11.5	13.2	14.8	16.5	22.0	25.2	28.9	30.9	32.1
C90 - D80	11.5	13.2	14.8	16.5	22.0	25.2	28.9	30.9	32.1

THANKS FOR THE love

MB Lights
info@mblights.com.au
[[click here](#) for product enquiry]