

SAPPHIRE 2

**LED WEATHERPROOF IP54 OYSTER
MULTIMODE CIRCULAR EMERGENCY LIGHT**

The new and improved ultra-thin Sapphire 2 circular emergency light features a modern trimless appearance and provides a low glare, high-transmission general light source whilst producing brilliant illumination during an emergency.

The IP54-rated impact resistant circular enclosure also comes with a toolless push-fit mounting bracket for quick and easy installation, making it an all-round emergency lighting solution for a majority of common areas such as stairwells, apartments, hotels, schools and car parks.

-
-
-
-
-
-
-
-



Optional:



Project Name	Type	Qty
Comments		

Technical Specifications

Item	Part Number	STD-OYSTER	EMS-OYSTER
	Description	20W Tri-Colour LED Weatherproof IP54 Oyster	20W Tri-Colour LED Multimode Weatherproof IP54 Circular Emergency Oyster Light c/w Synthium™ Battery
Input	Voltage & Frequency	230VAC : 50Hz	
	Installation	Tool-less wall / ceiling mounting bracket with fly lead	
Output	Light Source	2200lm Tri-Colour (3000K / 4000K / 6000K) High Performance LED Array - 100,000 hours	
	Mode of Operation	Multimode - Maintained / Non-Maintained / Switchable	
	Power Consumption	23W (Maintained), 5W (Non-Maintained)	
	Emergency Duration	> 120 minutes	
Controls	Charger	N/A	16hr intelligent 3-stage charger with Synthium™ battery
	Protection	N/A	Overcharge, low voltage disconnect, overcurrent, short circuit
	Testing Facility	N/A	Manual internal test switch
	Indicators	N/A	Battery charger green LED
Physical	Construction	Diffuser - low glare opal polycarbonate, Chassis - Polycarbonate	
	Mounting	Surface mounted - ceiling or wall	
	Dimensions L x W x H	330mm x 330mm x 40mm	
	IP / IK Rating	IP54	
	Weight	2.0kg	
	Warranty	3 years	
Environment	Operating Temperature	1° to 40°C	
	Relative Humidity	0 to 95%	
Compliance	Standards	SAA Approval SAA148724	RCM / EMC, AS/NZS 2293, AS/NZS 60598.1
	AS/NZS 2293 Classification	N/A	C0 D50 C90 D50
Accessories	Replacement Battery	P/N: BAT-OYSTER: Synthium™ LiFePO ₄	
	Microwave Dimming Sensor	P/N: include suffix "/MWS" e.g. EMS-OYSTER/MWS	

NOTE: Product specifications subject to change without prior notice due to ongoing product improvement policy and changes to industry standards.

Dimensions

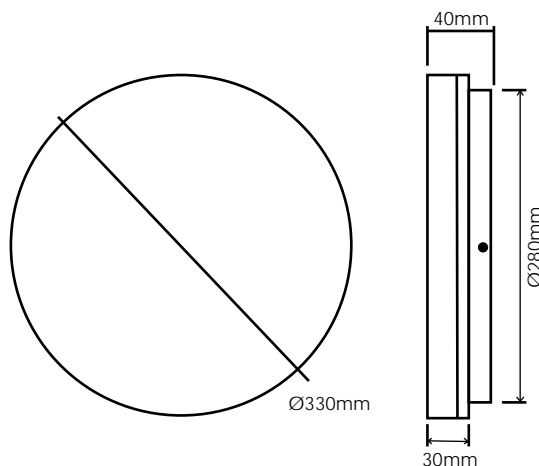

Spacing Table

SPACING TABLE		MOUNTING HEIGHT (m)								
NATA Classification		2.1	2.4	2.7	3.0	4.0	5.0	6.0	8.0	10.0
EMS-OYSTER	C0 - D50	11.5	13.2	14.8	16.5	21.8	23.1	24.1	25.4	25.8
	C90 - D50	11.5	13.2	14.8	16.5	21.8	23.1	24.1	25.4	25.8

