

EMERGENSEE™ ONE

D40 LED - RECESSED MOUNTED
NON-MAINTAINED ALL IN-ONE EMERGENCY LIGHT

The EmergenSee™ One takes advantage of innovative technology to integrate a lifetime-warranted ultra-bright LED, intelligent controls, and high capacity battery into one compact and aesthetically-pleasing unibody chassis.

This ceiling-recessible emergency light provides dependable and distinct illumination when it is needed the most can suits almost all internal general applications including offices, shopping centres, commercial properties, and residential buildings.



Project Name	Type	Qty
Comments		

Technical Specifications

Item	Part Number	EMS-ONE
	Description	D40 LED Recessed All-in-One Non-Maintained Emergency Light c/w <i>Synthium™</i> Battery
Input	Voltage & Frequency	230VAC ; 50Hz
	Installation	Complete with 1.2m flex cable & plug
Output	Light Source	High performance LED - lifetime warranty
	Mode of Operation	Non-Maintained
	Power Consumption	2W (standby)
	Emergency Duration	> 120 minutes
Controls	Charger	16hr intelligent 3-stage charger with <i>Synthium™</i> battery management system
	Protection	Overcharge, low voltage disconnect, overcurrent, short circuit
	Testing Facility	Manual test switch
	Indicators	Battery charger green LED
Physical	Construction	Flame-retardant polycarbonate
	Mounting	Recessed - ceiling, 70 - 150mm cut-out
	Dimensions L x W x H	Disc: 100mm or 160mm diameter
	IP Rating	IP20
	Weight	1.0kg
	Warranty	5 years on product
Environment	Operating Temperature	1° to 40°C
	Relative Humidity	0 to 95%
Compliance	Standards	RCM / EMC, AS/NZS 2293, AS/NZS 60598.1
	AS/NZS 2293 Classification	C0 D40 C90 D40
Accessories	Replacement Battery	P/N: BAT-ONE: <i>Synthium™</i> LiFePO ₄

NOTE: Product specifications subject to change without prior notice due to ongoing product improvement policy and changes to industry standards.

Dimensions

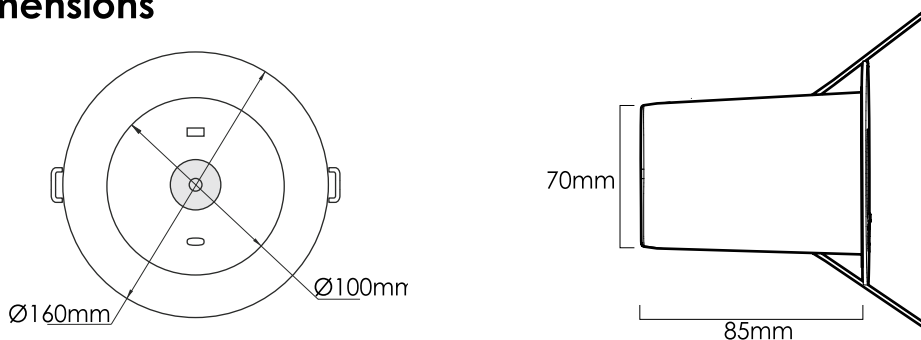

AS/NZS 2293.1:2018 Spacing Table

SPACING TABLE	MOUNTING HEIGHT (m)								
	2.1	2.4	2.7	3.0	4.0	5.0	6.0	8.0	10.0
C0 - D40	11.5	13.2	14.8	16.5	20.1	21.2	22.1	23.0	23.0
C90 - D40	11.5	13.2	14.8	16.5	20.1	21.2	22.1	23.0	23.0

THANKS
FOR THE
love

MB Lights
info@mblights.com.au
[[click here](#) for product enquiry]