



Electical Information	
Model No.	MBL-TCL450W-5K-BLK
Power Consumption (±5%)	450Watt / 600Watt
Power Supply	Sosen
Power Factor	>0.93, >0.90
Surge Protection	6kV line-line, 10kV line-earth
Driver Type	Constant Current
Control	Non- Dimmable, Photocell
	1-10V Dimmable

Optic Information	
LED Type	LED 5050
Luminous Flux (±10%)	65,250lm / 87,000lm
Efficacy (5000K Ra70)	145lm/w
Correlated Colour Temp	5000K (3000K, 4000K Optional)
Colour Rendering Index	>70
Beam Angle	R10502, R10503, R105034, R10505, R10506, R10507, R10508
UGR Level	N/A

Dimensions and Mount	
Dimensions	621 x 601 x 104mm (450w - 16.8kg) (600w - 18.3kg)
Mounting Option	Post Top Mount - Side Entry Mount / Wall Mount - Straight Arm
Material	Aluminum Alloy, Polycarbonate Optical Lens
Finish	Powder Coating
Fixture Colour	Black
IK Rating	IK08
IP Rating	IP66

Lifespan and Warranty	
Operation Temperature	-30°C ~ +50°C
Life Time of LED @ Ta=25 °C	49,000 hrs-L90
	110,000 hrs-L80
Warranty	5 Year



Photocell Control
 ON/OFF automatically according
 to day light.
 Model No. MBL-TCL-SEN



House-side Shield.
 PC Material for back light control
 Model No. MBL-TCL-SHIELD



U Bracket
 Wall mounting or pole top mount.
 Model No. MBL-TCL-U

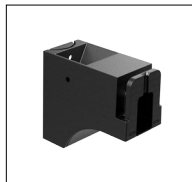

Straight Arm mount adaptor.
 100x100mm Square Pole
 Model No. MBL-TCL-SAA

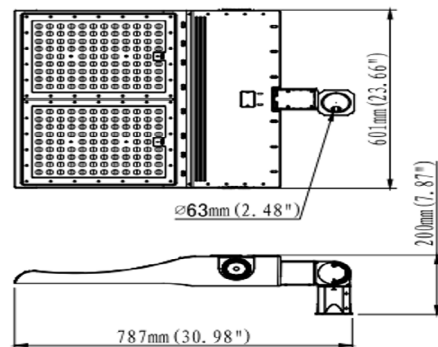

Project Name	Type	Qty
Comments		